

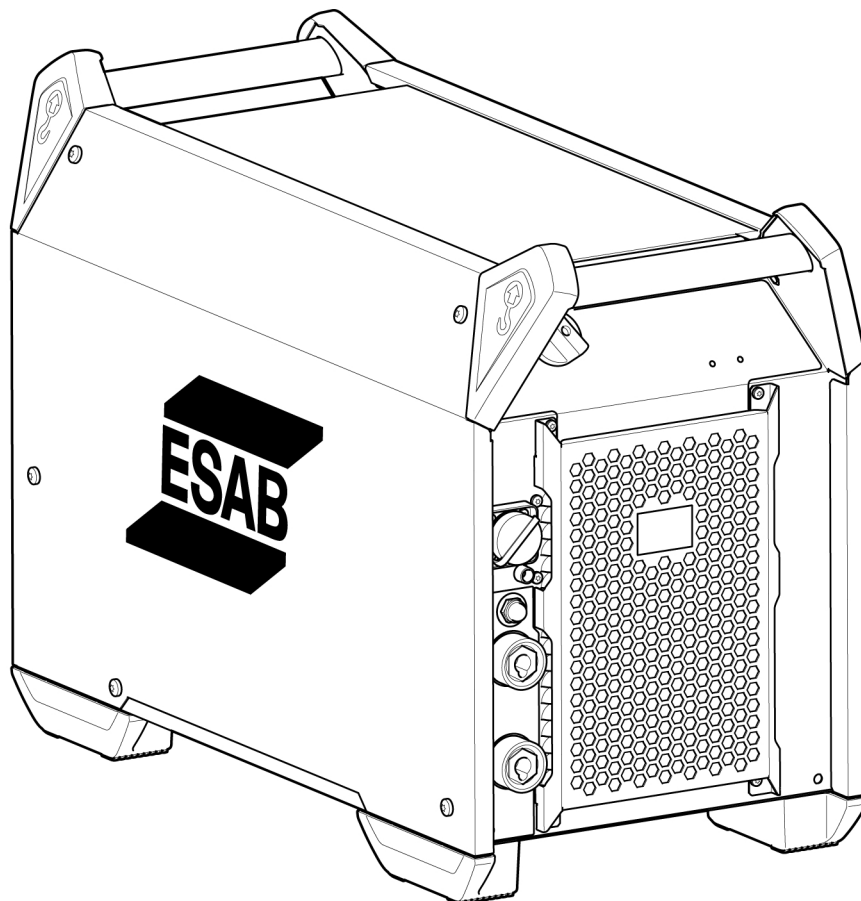

Aristo® 500ix



Instruction manual **Original instructions**



UK DECLARATION OF CONFORMITY

According to:

- Electric Equipment (Safety) Regulations 2016;
- Electromagnetic Compatibility Regulations 2016;
- The Restriction of the Use of Certain Hazardous Substances in Electrical and Electronic Equipment Regulations 2012 (as amended)
- The Ecodesign for Energy-Related Products and Energy Information Regulations 2021

Type of equipment

Arc welding power source

Type designation

500ix from serial number 941 xxx xxxx (2019 w41)

Brand name or trademark

ESAB

Manufacturer or his authorised representative established within United Kingdom

ESAB Group (UK) Ltd,
322 High Holborn, London, WC1V 7PB, United Kingdom
www.esab.co.uk

The following British Standards and Instruments in force within the United Kingdom has been used in the design:

- EN IEC 60974-1:2018/A1:2019	Arc welding equipment - Part 1: Welding power sources
- EN 60974-10:2014	Arc welding equipment - Part 10: Electromagnetic compatibility (EMC)
- UK S.I. 2021/745	Requirements for welding equipment pursuant to the Ecodesign for Energy-Related Products and Energy Information Regulations 2021

Additional Information:

Restrictive use, Class A equipment, intended for use in locations other than residential.

By signing this document, the undersigned declares as manufacturer, or the manufacturer's authorised representative established within the UK, that the equipment in question complies with the safety and environmental requirements stated above.

500ix is part of the ESAB Aristo product family.

Signatures

Gary Kisby

Sales & Marketing Director,
ESAB Group UK & Ireland
London, 2022-06-10

**UK
CA**

TABLE OF CONTENTS

1	SAFETY	5
1.1	Meaning of symbols	5
1.2	Safety precautions	5
2	INTRODUCTION	8
2.1	Equipment	8
3	TECHNICAL DATA	9
4	INSTALLATION	11
4.1	Location	11
4.2	Lifting instructions	12
4.3	Mains supply	13
5	OPERATION	16
5.1	Connections and control devices	16
5.2	Symbols	17
5.3	Connection of welding and return cable	17
5.4	Turning the power source on/off	17
5.5	Fan control	18
5.6	Thermal protection	18
5.7	VRD (Voltage Reducing Device)	18
5.8	Remote control unit	18
5.9	Arc voltage feedback	18
6	MAINTENANCE	19
6.1	Routine maintenance	19
6.2	Power source	19
7	TROUBLESHOOTING	21
8	ORDERING SPARE PARTS	22
	ORDERING NUMBERS	23
	BLOCK DIAGRAM	24
	ACCESSORIES	25

1 SAFETY

1.1 Meaning of symbols

As used throughout this manual: Means Attention! Be Alert!

**DANGER!**

Means immediate hazards which, if not avoided, will result in immediate, serious personal injury or loss of life.

**WARNING!**

Means potential hazards which could result in personal injury or loss of life.

**CAUTION!**

Means hazards which could result in minor personal injury.

**WARNING!**

Before use, read and understand the instruction manual and follow all labels, employer's safety practices and Safety Data Sheets (SDSs).



1.2 Safety precautions

Users of ESAB equipment have the ultimate responsibility for ensuring that anyone who works on or near the equipment observes all the relevant safety precautions. Safety precautions must meet the requirements that apply to this type of equipment. The following recommendations should be observed in addition to the standard regulations that apply to the workplace.

All work must be carried out by trained personnel well-acquainted with the operation of the equipment. Incorrect operation of the equipment may lead to hazardous situations which can result in injury to the operator and damage to the equipment.

1. Anyone who uses the equipment must be familiar with:
 - its operation
 - location of emergency stops
 - its function
 - relevant safety precautions
 - welding and cutting or other applicable operation of the equipment
2. The operator must ensure that:
 - no unauthorised person is stationed within the working area of the equipment when it is started up
 - no-one is unprotected when the arc is struck or work is started with the equipment
3. The workplace must:
 - be suitable for the purpose
 - be free from drafts
4. Personal safety equipment:
 - Always wear recommended personal safety equipment, such as safety glasses, flame-proof clothing, safety gloves
 - Do not wear loose-fitting items, such as scarves, bracelets, rings, etc., which could become trapped or cause burns

5. General precautions:

- Make sure the return cable is connected securely
- Work on high voltage equipment **may only be carried out by a qualified electrician**
- Appropriate fire extinguishing equipment must be clearly marked and close at hand
- Lubrication and maintenance must **not** be carried out on the equipment during operation

**WARNING!**

Arc welding and cutting can be injurious to yourself and others. Take precautions when welding and cutting.

**ELECTRIC SHOCK - Can kill**

- Do not touch live electrical parts or electrodes with bare skin, wet gloves or wet clothing
- Insulate yourself from work and ground.
- Ensure your working position is safe

**ELECTRIC AND MAGNETIC FIELDS - Can be dangerous to health**

- Welders having pacemakers should consult their physician before welding. EMF may interfere with some pacemakers.
- Exposure to EMF may have other health effects which are unknown.
- Welders should use the following procedures to minimize exposure to EMF:
 - Route the electrode and work cables together on the same side of your body. Secure them with tape when possible. Do not place your body between the torch and work cables. Never coil the torch or work cable around your body. Keep welding power source and cables as far away from your body as possible.
 - Connect the work cable to the workpiece as close as possible to the area being welded.

**FUMES AND GASES - Can be dangerous to health**

- Keep your head out of the fumes
- Use ventilation, extraction at the arc, or both, to take fumes and gases away from your breathing zone and the general area

**ARC RAYS - Can injure eyes and burn skin**

- Protect your eyes and body. Use the correct welding screen and filter lens and wear protective clothing
- Protect bystanders with suitable screens or curtains

**NOISE - Excessive noise can damage hearing**

Protect your ears. Use earmuffs or other hearing protection.

**MOVING PARTS - Can cause injuries**

- Keep all doors, panels and covers closed and securely in place. Have only qualified people remove covers for maintenance and troubleshooting as necessary. Reinstall panels or covers and close doors when service is finished and before starting engine.



- Stop engine before installing or connecting unit.
- Keep hands, hair, loose clothing and tools away from moving parts.

**FIRE HAZARD**

- Sparks (spatter) can cause fire. Make sure therefore that there are no inflammable materials nearby
- Do not use on closed containers.



HOT SURFACE - Parts can burn

- Do not touch parts bare handed.
- Allow cooling period before working on equipment.
- To handle hot parts, use proper tools and/or insulated welding gloves to prevent burns.

MALFUNCTION - Call for expert assistance in the event of malfunction.

PROTECT YOURSELF AND OTHERS!



CAUTION!

This product is solely intended for arc welding.



WARNING!

Do not use the power source for thawing frozen pipes.



CAUTION!

Class A equipment is not intended for use in residential locations where the electrical power is provided by the public low-voltage supply system. There may be potential difficulties in ensuring electromagnetic compatibility of class A equipment in those locations, due to conducted as well as radiated disturbances.

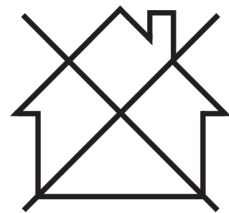

NOTE!

Dispose of electronic equipment at the recycling facility!

In observance of European Directive 2012/19/EC on Waste Electrical and Electronic Equipment and its implementation in accordance with national law, electrical and/or electronic equipment that has reached the end of its life must be disposed of at a recycling facility.

As the person responsible for the equipment, it is your responsibility to obtain information on approved collection stations.

For further information contact the nearest ESAB dealer.

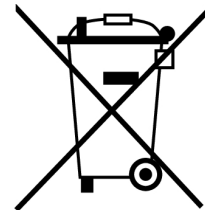

ESAB has an assortment of welding accessories and personal protection equipment for purchase. For ordering information contact your local ESAB dealer or visit us on our website.

2 INTRODUCTION

The power source **Aristo® 500ix** combined with U6, U8₂ or MA25 Pulse panels offer a complete multi-process package supporting MIG, pulse MIG, TIG and gouging, depending on which feeder it is used with.

The power source is intended for use with the wire feed unit **RobustFeed U6**, **RobustFeed U82**, **RobustFeed Pulse**, Feed 3004/4804 or YardFeed 2000 and the cooling unit COOL 2. For more information about the feed units and the cooling unit, refer to the Instruction information for the specific product.

ESAB accessories for the product can be found in the "ACCESSORIES" chapter of this manual.

2.1 Equipment

The power source is supplied with:

- 5 m (16 ft) return cable with earth clamp
- 5 m (16 ft) mains cable
- Instruction manual
- Safety instruction manual
- Quick start guide

3 TECHNICAL DATA

Aristo® 500ix			
Mains voltage	380-460 V, $\pm 10\%$, 3~ 50/60 Hz		
Mains supply $S_{sc\ min}$	7.2 MVA		
Primary current I_{max}	380 V	400 V	460 V
MIG/MAG	38 A	35 A	30 A
MMA	40 A	35 A	31 A
TIG	30 A	27 A	24 A
Idle power	24 W	25 W	27 W
Setting range (DC)			
MIG/MAG	16 A / 14.8 V - 500 A / 39 V		
MMA	16 A / 20.6 V - 500 A / 40 V		
TIG	5 A / 10.2 V - 500 A / 30 V		
Permissible load at MIG/MAG			
60 % duty cycle	500 A / 39.0 V		
100% duty cycle	400 A / 34.0 V		
Permissible load at MMA			
60 % duty cycle	500 A / 40.0 V		
100% duty cycle	400 A / 36.0 V		
Permissible load at TIG			
60 % duty cycle	500 A / 30.0 V		
100% duty cycle	400 A / 26.0 V		
Power factor at maximum current	0.91		
Efficiency at maximum current	88 %		
Open circuit voltage	58 V		
Operating temperature	-20 to 40 °C (-4 to 104 °F)		
Transport temperature	-20 to 55 °C (-4 to 131 °F)		
Constant sound pressure when idling	<70 dB (A)		
Dimensions l×w×h	712 × 325 × 470 mm (28.0 × 12.8 × 18.5 in.)		
Weight	58.5 kg (128.9 lb)		
Insulation class	H		
Enclosure class	IP23		
Application classification	S		

Mains supply, $S_{sc\ min}$

Minimum short circuit power on the network in accordance with IEC 61000-3-12.

Duty cycle

The duty cycle refers to the time as a percentage of a ten-minute period that you can weld or cut at a certain load without overloading. The duty cycle is valid for 40 °C / 104 °F, or below.

Enclosure class

The **IP** code indicates the enclosure class, i.e. the degree of protection against penetration by solid objects or water.

Equipment marked **IP23** is intended for indoor and outdoor use.

Application class

The symbol **S** indicates that the power source is designed for use in areas with increased electrical hazard.

Class-H insulations can withstands a temperature of up to 180°C. It is made of inorganic material glued with silicone resin or adhesives of equivalent performance.

4 INSTALLATION

The installation must be carried out by a professional.

The equipment used together with Aristo® 500ix must have at least the following program versions in order for the power source to work properly:

- for RobustFeed U8₂: 3.02G or later
- for RobustFeed U6: 2.16P or later
- for MA25 Pulse: 1.88H or later

4.1 Location

Position the welding power source such way that its cooling air inlets and outlets are not obstructed.

4.2 Lifting instructions

Max 80.3 kg/177 lbs

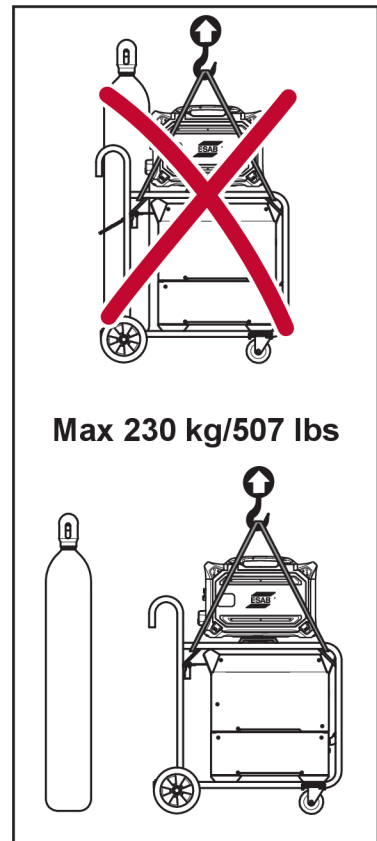
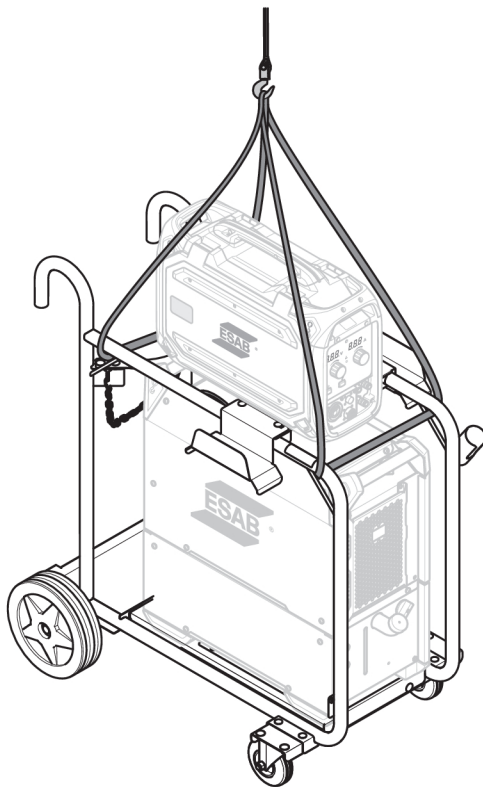
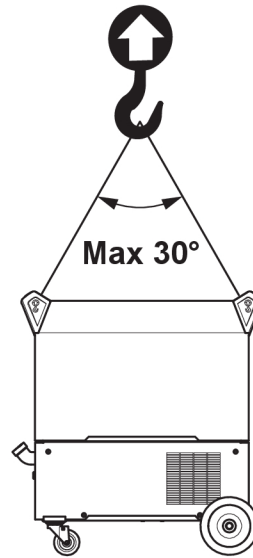
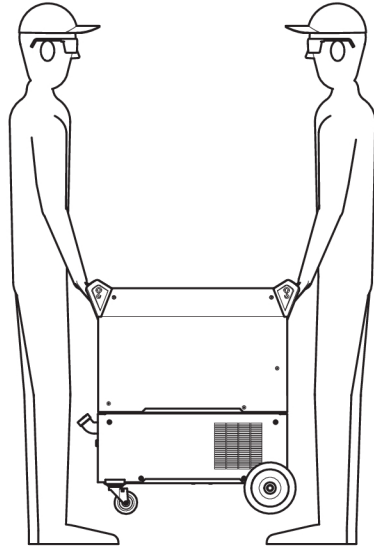



WARNING!

Secure the equipment - particularly if the ground is uneven or sloping.

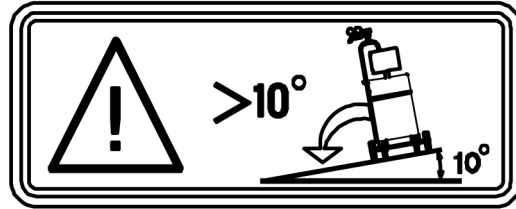

4.3 Mains supply



NOTE!

Mains supply requirements

This equipment complies with IEC 61000-3-12 provided that the short-circuit power is greater than or equal to S_{scmin} at the interface point between the user's supply and the public system. It is the responsibility of the installer or user of the equipment to ensure, by consultation with the distribution network operator if necessary, that the equipment is connected only to a supply with a short-circuit power greater than or equal to S_{scmin} . Refer to the technical data in the TECHNICAL DATA chapter.

Make sure that the welding power source is connected to the correct supply voltage and that it is protected by the correct fuse rating. A protective earth connection must be made in accordance with regulations.

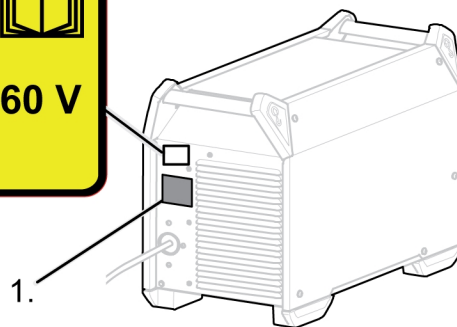
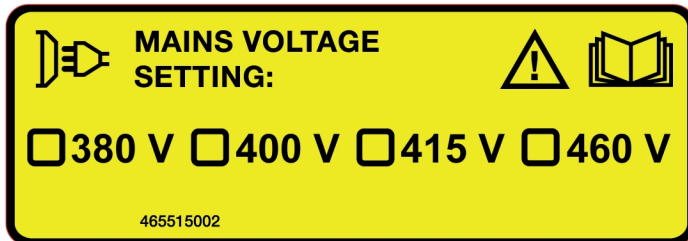

1. Rating plate with supply connection data

Recommended fuse sizes and minimum cable area Aristo® 500ix

Aristo® 500ix			
Mains voltage	380 V 3~ 50/60 Hz	400 V 3~ 50/60 Hz	460 V 3~ 50/60 Hz
Mains cable area	4 × 6 mm ²	4 × 6 mm ²	4 × 6 mm ²
Maximal current rating I_{max}	40 A	35 A	31 A
I_{1eff}			
MIG/MAG	30 A	27 A	24 A
MMA	31 A	25 A	24 A
TIG	24 A	21 A	19 A

Fuse			
anti-surge	35 A	35 A	35 A
type C MCB	32 A	32 A	32 A

NOTE!
The mains cable areas and fuse sizes as shown above are in accordance with Swedish regulations. Use the power source in accordance with the relevant national regulations.

Supply from power generators

The power source can be supplied from different types of generators. However, some generators may not provide sufficient power for the welding power source to operate correctly. Generators with Automatic Voltage Regulation (AVR) or with equivalent or better type of regulation, with rated power ≥ 40 kW, are recommended.

Connection instruction

WARNING!
The mains supply must be disconnected during installation.

WARNING!
Wait until the DC bus capacitors are discharged. The DC bus capacitor discharge time is at least 2 minutes!

The power source is factory set to 400 V AC. If another mains voltage setting is required, the cable on the printed circuit board has to be moved and put in the correct position. Also the label, at the rear of the power source, marked with the mains voltage setting must be updated. This operation must be done by a person who has the appropriate electrical knowledge.

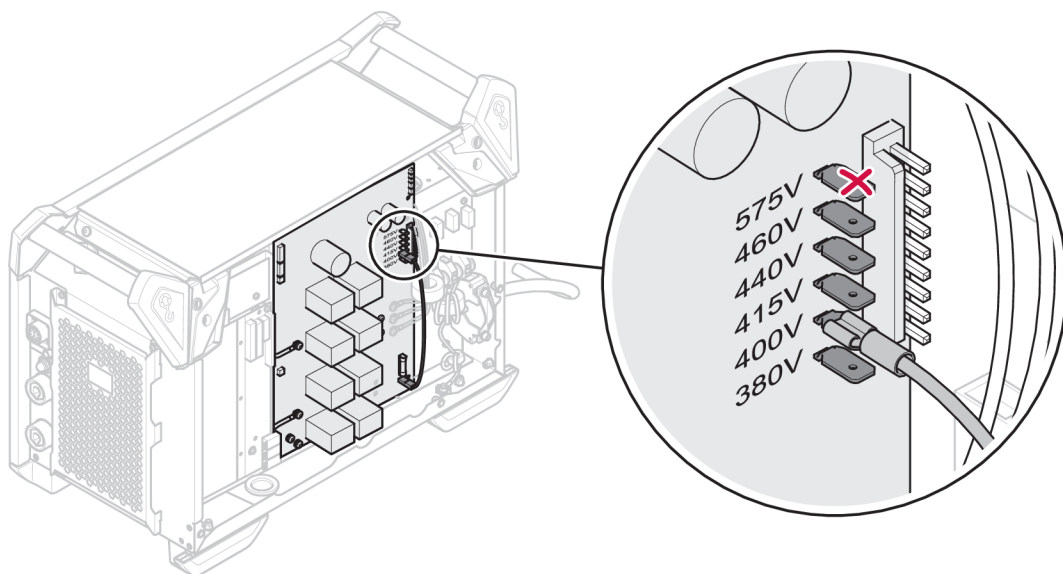

NOTE!
This power source version is designed for a nominal input voltage from 380 to 460 V AC. This means that the hardware to support 575 V input is not available, 575 V tab is not connected.

If the mains cable needs to be changed, the earth connection to the bottom plate and the ferrites must be installed correctly. See the picture below for the installation order of the ferrites, washers, nuts and screws.

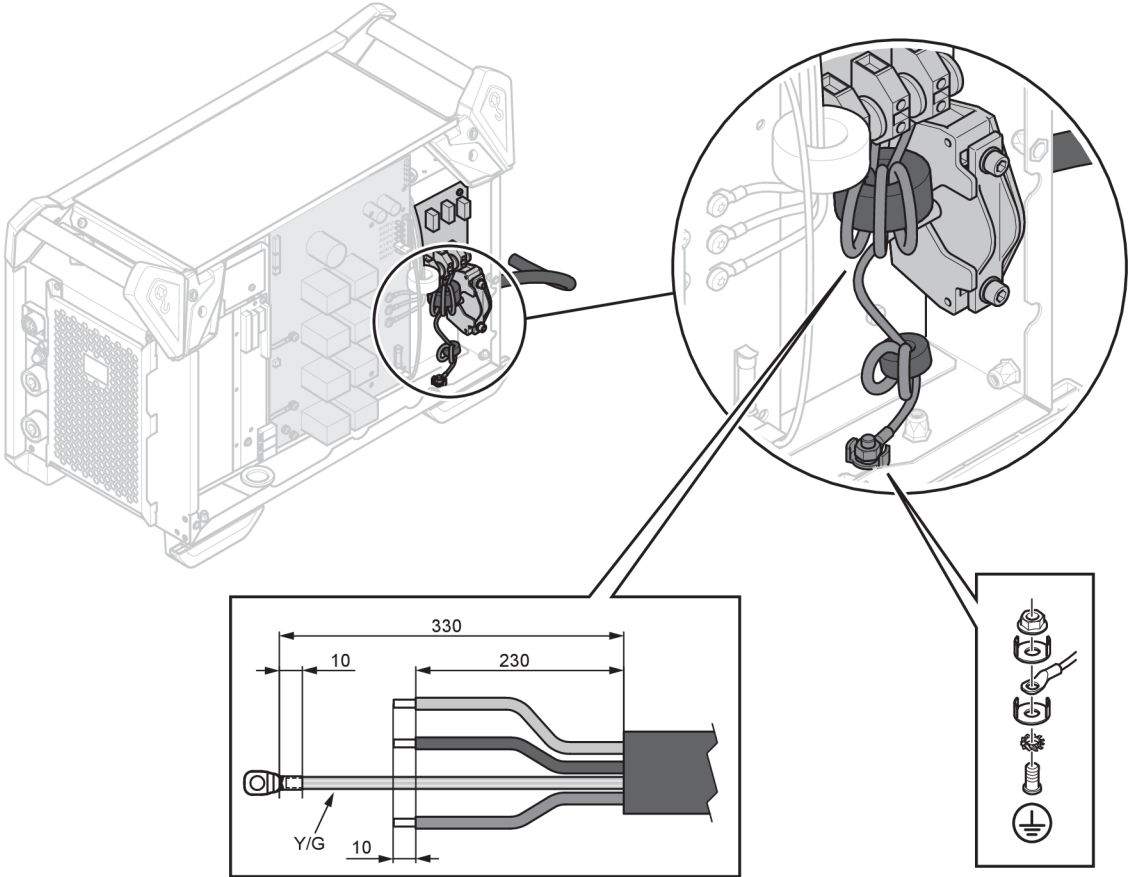

5 OPERATION

General safety regulations for handling the equipment can be found in the "SAFETY" chapter of this manual. Read it through before you start using the equipment!



NOTE!

When moving the equipment use intended handle. Never pull the cables.



WARNING!

Electric shock! Do not touch the workpiece or the welding head during operation!



NOTE!

To achieve the best possible result at Mig short pulsing, the welding and return cables must not exceed 10 m (33 ft).



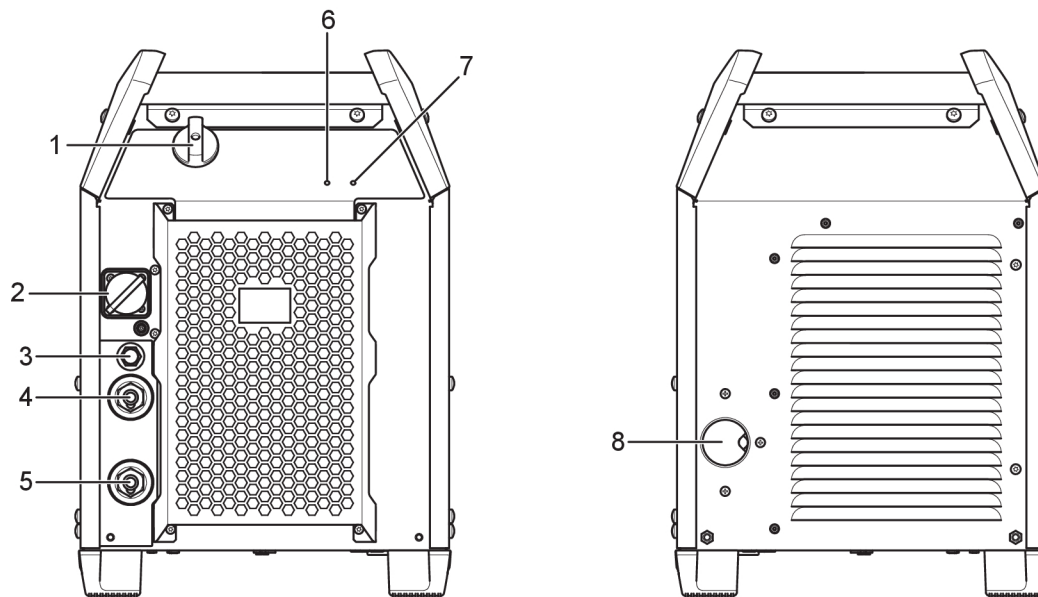

5.1 Connections and control devices



1. Mains power supply switch, O / I
2. Connection for wire feed unit
3. Fuse (10 A) for supply voltage (42 VAC) for feeder unit
4. Positive welding terminal: Welding cable

5. Negative welding terminal: Return cable
6. Indicating LED, overheating
7. Indicating LED, power supply ON
8. Mains cable inlet

5.2 Symbols

	Power supply ON (4)		Overheating (3)
	Protective earth		Positioning of lifting eye

5.3 Connection of welding and return cable

The power source has two outputs, a positive terminal (+) and a negative terminal (-), for connecting welding and return cables.

Connect the return cable to the negative terminal on the power source. Secure the return cable's contact clamp to the work piece and ensure that there is good contact between the work piece and the output for the return cable on the power source.

Recommended maximum current values for connection set cables

At an ambient temperature of +25 °C and normal 10 minutes cycle:

Cable area	Duty cycle		Voltage loss / 10 m
	100%	60%	
50 mm ²	290	320	0.35 V / 100 A
70 mm ²	360	400	0.25 V / 100 A
95 mm ²	430	500	0.19 V / 100 A

At an ambient temperature of +40 °C and normal 10 minutes cycle:

Cable area	Duty cycle		Voltage loss / 10 m
	100%	60%	
50 mm ²	250	280	0.37 V / 100 A
70 mm ²	310	350	0.27 V / 100 A
95 mm ²	370	430	0.20 V / 100 A

Duty cycle

The duty cycle refers to the time as a percentage of a ten-minute period that you can weld or cut at a certain load without overloading. The duty cycle is valid for 40 °C (104 °F).

5.4 Turning the power source on/off

Turn the power source on by turning switch (1) to the "I" position. Turn the power source off by turning the switch (1) to the "O" position. Regardless the mains supply is interrupted abnormally or the power source is switched off in the normal manner, the welding data will be stored, so it will be available next time the unit is turned on.

5.5 Fan control

The power source has a time control that means that the fans continue to run for 6.5 minutes after welding has stopped, and the power source switches to energy-saving mode. The fans start again when welding restarts.

5.6 Thermal protection

The welding power source has thermal protection circuit that operates if the internal temperature becomes too high. If this occurs the welding current is blocked and the indicating LED (6) lights. The thermal protection resets automatically when the temperature has fallen within normal operation temperature.

5.7 VRD (Voltage Reducing Device)

The VRD function ensures that the open-circuit voltage does not exceed 35 V when welding is not being carried out. The VRD function must be activated by a qualified service technician, by means of ESAT (ESAB Software Administration Tool, a kit for technical service including a software to manage settings, update of software etc.).

The VRD function is blocked when the system senses that welding has started.

5.8 Remote control unit

For more information about the operation of the remote control unit, see the instruction information for the control panel.

5.9 Arc voltage feedback

To achieve a good welding result, the arc voltage feedback is a crucial factor. In MIG/MAG welding, the power source is prepared to sense the arc voltage in the wire feeder. Prerequisite for this functionality is that an ESAB wire feeder and an ESAB interconnection cable is used! This method of measuring the arc voltage, compensates for the voltage drop in the welding cable to the wire feeder. With an ESAB torch supporting "TrueArcVoltage", the voltage drop all the way to the contact tip is compensated.

**NOTE!**

To compensate the voltage drop in the return cable, the power source can be configured (by authorised ESAB service personnel) to use an external arc voltage sense wire from the workpiece.

6 MAINTENANCE

**WARNING!**

The mains supply must be disconnected during cleaning and maintenance.

**CAUTION!**

Only persons with the appropriate electrical knowledge (authorised personnel) may remove the safety plates.

**CAUTION!**

The product is covered by manufacturer's warranty. Any attempt to carry out repair work by non-authorised service centers or personnel will invalidate the warranty.

**NOTE!**

Regular maintenance is important for safe and reliable operation.

**NOTE!**





Perform maintenance more often during severe dusty conditions.

Before each use - make sure that:

- Product and cables are not damaged,
- The torch is clean and not damaged.

6.1 Routine maintenance

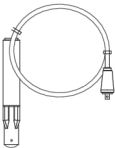
Maintenance schedule during normal conditions. Check equipment prior to every use.

Interval	Area to maintain		
Every 3 months	 Clean or replace unreadable labels.	 Clean weld terminals.	 Check or replace weld cables.
Every 6 months	 Clean inside equipment. Use dry compressed air with reduced pressure.		

6.2 Power source

To maintain the performance and increase the lifetime of the power source it is mandatory to clean the product regularly. How often depends on:

- the welding process
- the arc time

- the working environment
- the surrounding environment, that is grinding etc.

Tools needed for the cleaning procedure:

- torx screwdriver, T25 and T30
- dry compressed air at a pressure of 4 bar
- protective equipment like ear plugs, safety glasses, masks, gloves and safety shoes

Cleaning procedure

CAUTION!
Make sure that the cleaning procedure is done in a suitable prepared workspace.

CAUTION!
The cleaning procedure should be carried out by authorised service technician.

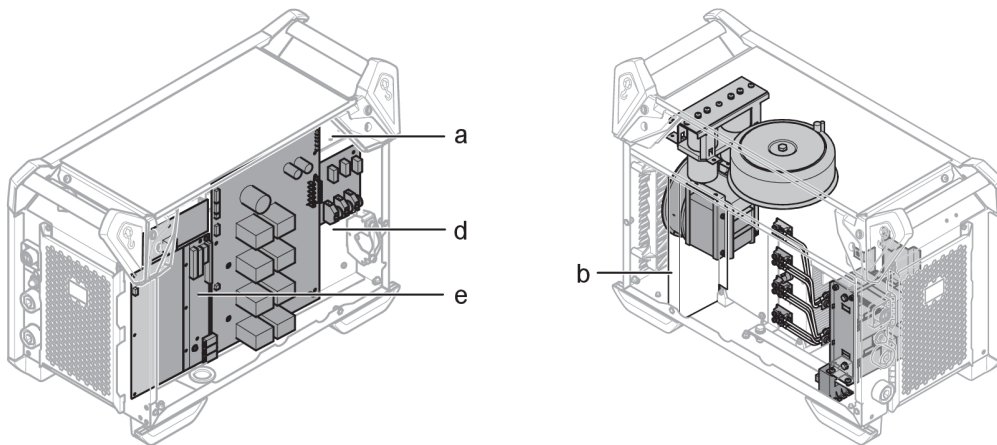

1. Disconnect the mains supply.
2. Wait for 4 minutes to discharge the capacitors.
3. Remove the side panels on the power source.
4. Remove the top panel on the power source.
5. Remove the plastic cover between the heat sink and fan (b).
6. Clean the power source with dry compressed air (4 bar) as follows:
 - a) The upper rear part.
 - b) From the rear panel through the secondary heat sink.
 - c) The inductor, transformer and current sensor.
 - d) The power components side, from the rear side behind PCB 15AP1.
 - e) The PCBs at both sides.
7. Make sure that there is no dust left on any part.
8. Install the plastic cover between the heat sink and the fan (b) and make sure it is correctly fitted against the heat sink.
9. Reassemble the power source after cleaning and perform testing according to IEC 60974-4. Follow the procedure in section “After repair, inspection and test” in the Service manual.

7 TROUBLESHOOTING

Try these recommended checks and inspections before sending for an authorised service technician.

Type of fault	Corrective action
No arc.	<ul style="list-style-type: none"> • Check that the mains power supply switch is turned on. • Check that the mains, welding and return cables are correctly connected. • Check that the correct current value is set. • Check the mains power supply fuses.
The welding current is interrupted during welding.	<ul style="list-style-type: none"> • Check whether the thermal protection trip has operated (indicated by the orange LED on the front (6)) • Check the main power supply fuses if the LED indicating power supply (7) is not lit.
The thermal protection trips frequently.	<ul style="list-style-type: none"> • Make sure that you are not exceeding the rated data for the power source (i.e. that the unit is not being overloaded). • Check that the ambient temperature is not above the one for the rated duty cycle 40 °C/104 °F.
Poor welding performance.	<ul style="list-style-type: none"> • Check that the welding current supply and return cables are correctly connected. • Check that the correct current value is set. • Check that the correct welding wires are being used. • Check the main power supply fuses.

8 ORDERING SPARE PARTS



CAUTION!

Repair and electrical work should be performed by an authorised ESAB service technician.
Use only ESAB original spare and wear parts.

Aristo® 500ix is designed and tested in accordance with the international and European standards **IEC/EN 60974-1** and **IEC/EN 60974-10 Class A**, Canadian standards **CAN/CSA-E60974-1** and US standards **ANSI/IEC 60974-1**. On completion of service or repair work, it is the responsibility of the person(s) performing the work to ensure that the product still complies with the requirements of the above standards.

Spare parts and wear parts can be ordered through your nearest ESAB dealer, see [esab.com](https://www.esab.com). When ordering, please state product type, serial number, designation and spare part number in accordance with the spare parts list. This facilitates dispatch and ensures correct delivery.

APPENDIX

ORDERING NUMBERS

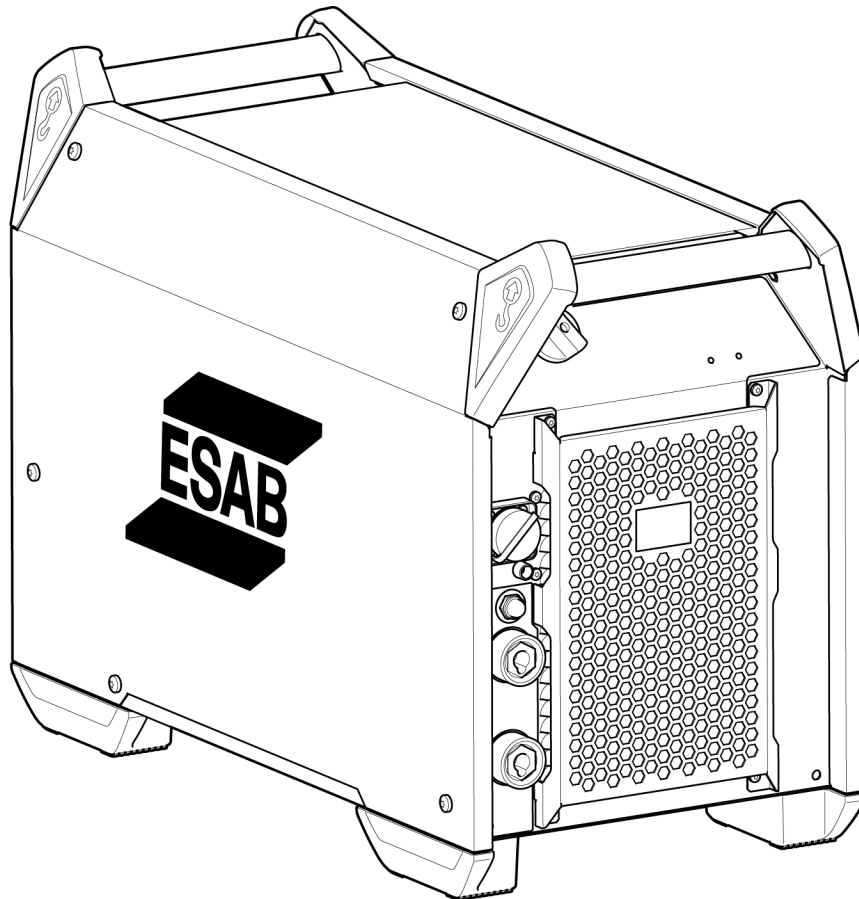

Ordering number	Denomination	Type	Notes
0446 200 880	Power source	Aristo® 500ix	CE
0446 200 881	Power source	Aristo® 500ix	CSA
0446 200 882	Power source	Aristo® 500ix	AUS
0446 200 883	Power source	Aristo® 500ix	CCC
0463 696 *	Instruction manual		
0463 700 001	Service manual		
0460 701 001	Spare parts list		



The three last digits in the document number show the version of the manual. Therefore they are replaced with * here. Make sure to use a information with a serial number or software version that corresponds with the product, see the front page of the manual.

Technical documentation is available on the Internet at: www.esab.com

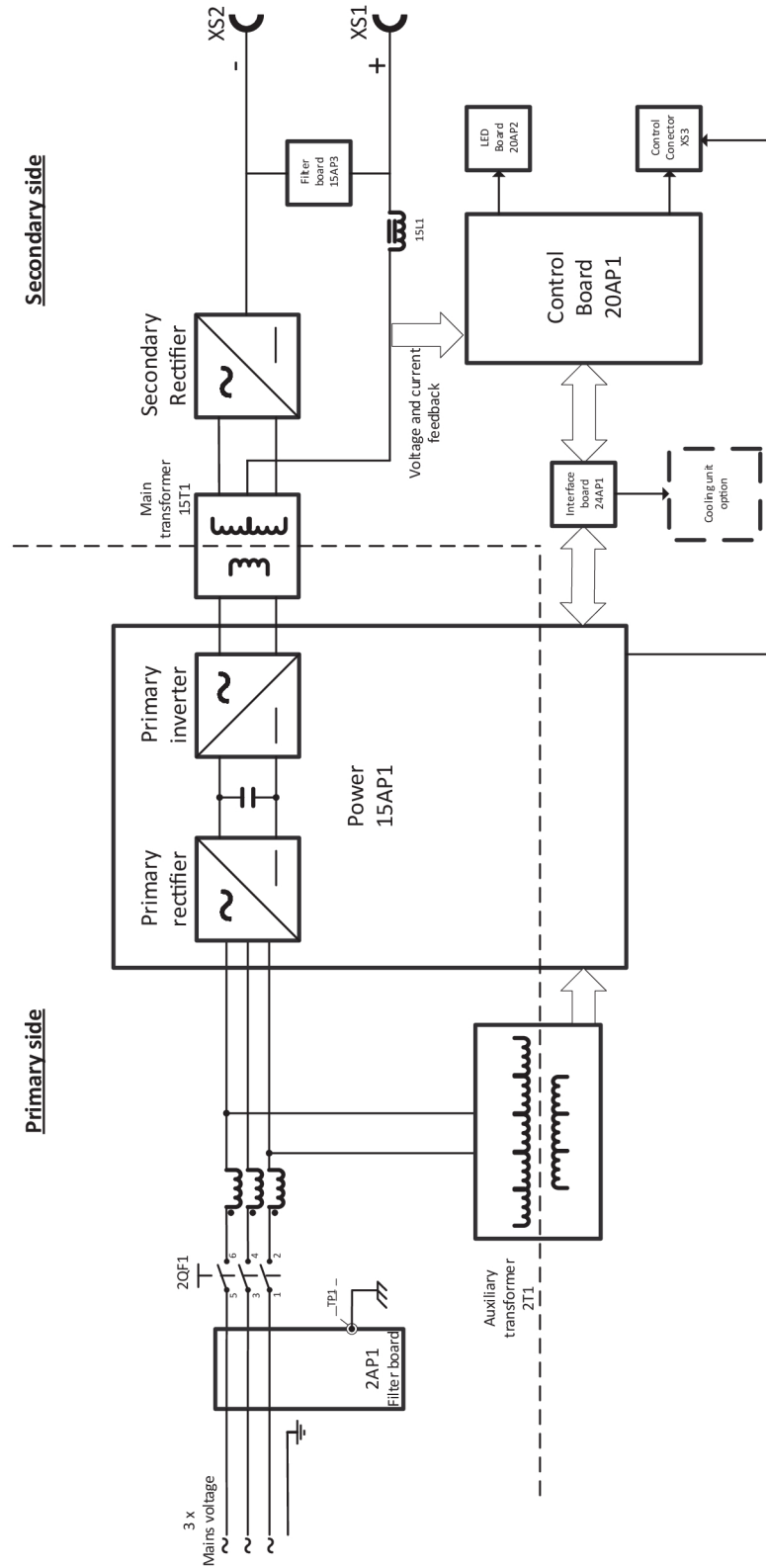

BLOCK DIAGRAM





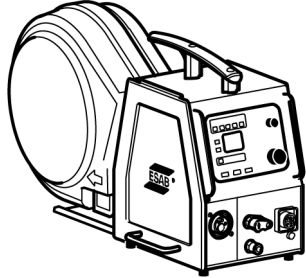
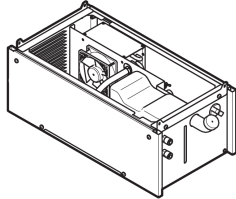
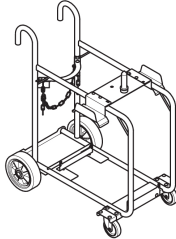
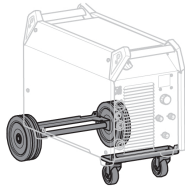

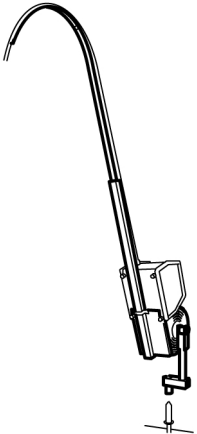
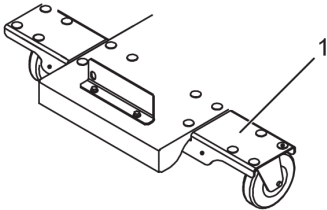

ACCESSORIES

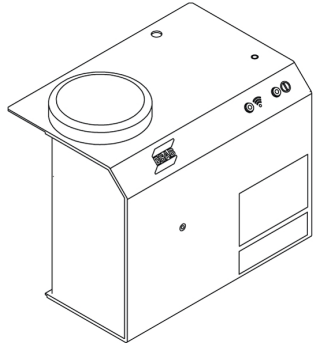
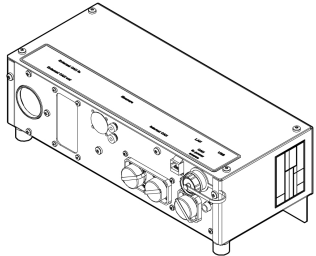
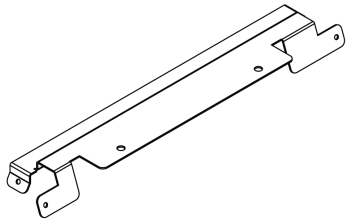
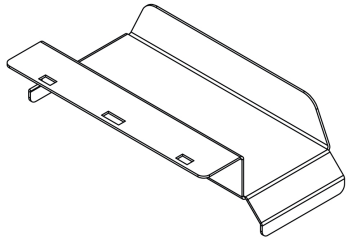
Wire feeders		
0445 800 894	RobustFeed Pulse, water-cooled	
0445 800 891	RobustFeed Pulse, water-cooled, heater, MMA outlet and flow meter included	
0445 800 892	RobustFeed Pulse, water-cooled, Push-Pull, heater, MMA outlet and flow meter included	
0445 800 887	RobustFeed U6, water-cooled, heater, MMA outlet and flow meter included	
0445 800 888	RobustFeed U6, water-cooled, Push-Pull, heater, MMA outlet and flow meter included	
0445 800 902	RobustFeed U6, water-cooled, Push-Pull, heater, flow meter, MMA outlet included and VRD activated	
0445 800 897	RobustFeed U6, water-cooled	
0445 800 898	RobustFeed U82 offshore, water-cooled, heater, Push-pull, flow meter and MMA outlet	
0445 800 899	RobustFeed U82, water-cooled	
0445 800 900	RobustFeed U82 offshore, water-cooled, Push-Pull, heater, flow meter and MMA outlet	
0445 800 901	RobustFeed U0, water-cooled	
0445 800 903	RobustFeed U82 offshore, water-cooled, Push-Pull, heater, flow meter, MMA outlet and VRD activated	

0460 526 670	Aristo® Feed 3004 MA25 Pulse AI	
0460 526 671	Aristo® Feed 3004w MA25 Pulse AI	
0460 526 672	Aristo® Feed 3004 MA25 Pulse Steel	
0460 526 673	Aristo® Feed 3004w MA25 Pulse Steel	
0460 526 886	Aristo® Feed 3004 U6	
0460 526 896	Aristo® Feed 3004w U6	
0460 526 881	Aristo® Feed 3004 U8₂ , (U8 ₂ not included)	
0460 526 891	Aristo® Feed 3004w U8₂ , (U8 ₂ not included)	
0460 526 996	Aristo® Feed 4804w U6	
0460 526 991	Aristo® Feed 4804w U8₂ , (U8 ₂ not included)	
0459 906 896	Yardfeed 2000w U6 , for 200mm (8 in.) spools	
0465 427 880	Cooling unit, Cool2	
0349 313 450	Trolley , compatible with RobustFeed and Aristo® Feed 3004	
0465 416 880	Wheel kit	

0458 705 880	<p>Counter balance device, for Aristo® Feed 3004 (not RobustFeed)</p> <p>for 300 mm (11 in.) spools. Includes mast and counter balance</p> <p><i>For use of the counter balance device, a stabilizer kit is required!</i></p> <p><i>IP23 protection is not valid for wire feeder with counterbalance arm!</i></p>	
0465 509 880	<p>Stabilizer kit</p>	
<p>Control units</p>		
0460 820 880	<p>Aristo® U8₂, complete including holder</p>	
0460 820 881	<p>Aristo® U8₂ Plus, complete including holder</p>	

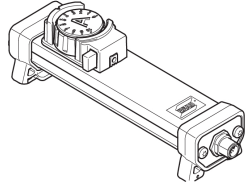
Aristo® 500ix Weldcloud solution - For detailed instructions, see Assembly Instruction 0446 944 001.		
0464 550 800	Weldcloud mobile	
0460 891 886	Aristo® W8₂ Data	
0446 712 880	W82 Mounting bracket	
0446 877 880	Cable mounting bracket	
0462 000 880	12 pol male burndy cable	
0446 089 880	Adaptor cable	

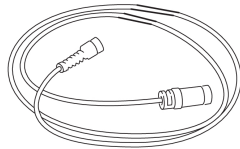
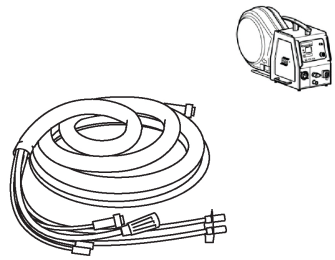
Remote controls		
0459 491 880	Remote control MTA1	
0459 491 896	Remote control unit AT1 MMA and TIG current	
0459 491 897	Remote control unit AT1 CF MMA and TIG: course and fine setting of current	
0459 491 911	Remote control adapter RA 23	
Remote control cable 12 pole - 8 pole		
0459 552 880	5 m (16 ft 4.85 in.)	
0459 552 881	10 m (32 ft 9.7 in.)	
0459 552 882	15 m (49 ft 2.55 in.)	
0459 552 883	25 m (82 ft 0.25 in.)	
Aristo® Feed 3004 Interconnection cables, gas-cooled, 70 mm², 10 poles		
0459 528 780	1.7 m (5 ft 6.93 in.)	
0459 528 781	5 m (16 ft 4.85 in.)	
0459 528 782	10 m (32 ft 9.7 in.)	
0459 528 783	15 m (49 ft 2.55 in.)	
0459 528 784	25 m (82 ft 0.25 in.)	
0459 528 785	35 m (114 ft 9.95 in.)	

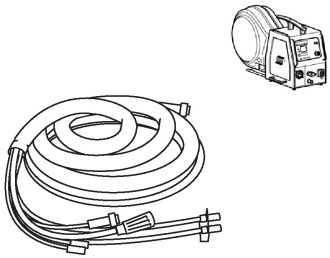
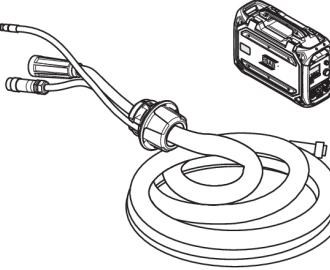
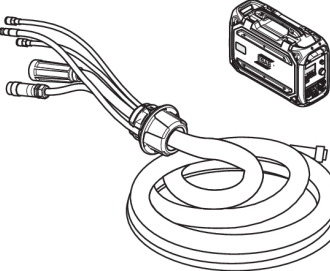
Aristo® Feed 3004 Interconnection cables, water-cooled, 70 mm², 10 poles		
0459 528 790	1.7 m (5 ft 6.93 in.)	
0459 528 791	5 m (16 ft 4.85 in.)	
0459 528 792	10 m (32 ft 9.7 in.)	
0459 528 793	15 m (49 ft 2.55 in.)	
0459 528 794	25 m (82 ft 0.25 in.)	
0459 528 795	35 m (114 ft 9.95 in.)	
RobustFeed U6 and RobustFeed Pulse, Interconnection cables with pre-assembled strain relief, gas-cooled, 70 mm², 10 poles		
0446 255 880	2 m (6 ft 6.74 in.)	
0446 255 881	5 m (16 ft 4.85 in.)	
0446 255 882	10 m (32 ft 9.7 in.)	
0446 255 883	15 m (49 ft 2.55 in.)	
0446 255 884	20 m (65 ft 7.4 in.)	
0446 255 885	25 m (82 ft 0.25 in.)	
0446 255 886	35 m (114 ft 9.95 in.)	
RobustFeed U6 and RobustFeed Pulse, Interconnection cables with pre-assembled strain relief, water-cooled, 70 mm², 10 poles		
0446 255 890	2 m (6 ft 6.74 in.)	
0446 255 891	5 m (16 ft 4.85 in.)	
0446 255 892	10 m (32 ft 9.7 in.)	
0446 255 893	15 m (49 ft 2.55 in.)	
0446 255 894	20 m (65 ft 7.4 in.)	
0446 255 895	25 m (82 ft 0.25 in.)	
0446 255 896	35 m (114 ft 9.95 in.)	



A WORLD OF PRODUCTS AND SOLUTIONS.



For contact information visit <http://esab.com>

ESAB AB, Lindholmsallén 9, Box 8004, 402 77 Gothenburg, Sweden, Phone +46 (0) 31 50 90 00

manuals.esab.com



**CEUK
CA**

